

DETAIL: SANITARY SEWER INSTALLATION DETAIL FOR ALL FRAMES AND COVERS

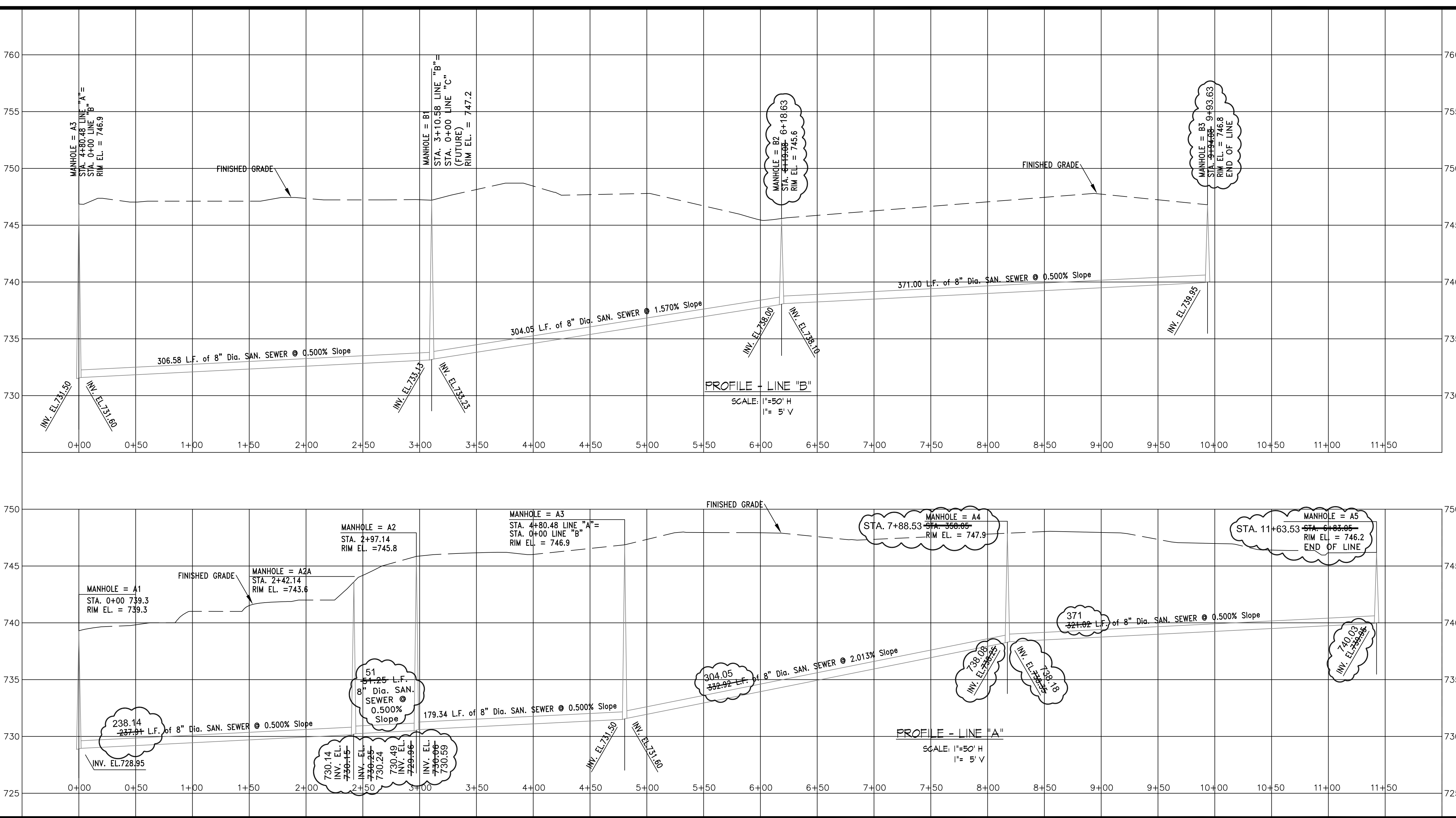

SANITARY SEWER - PROFILE & DETAILS

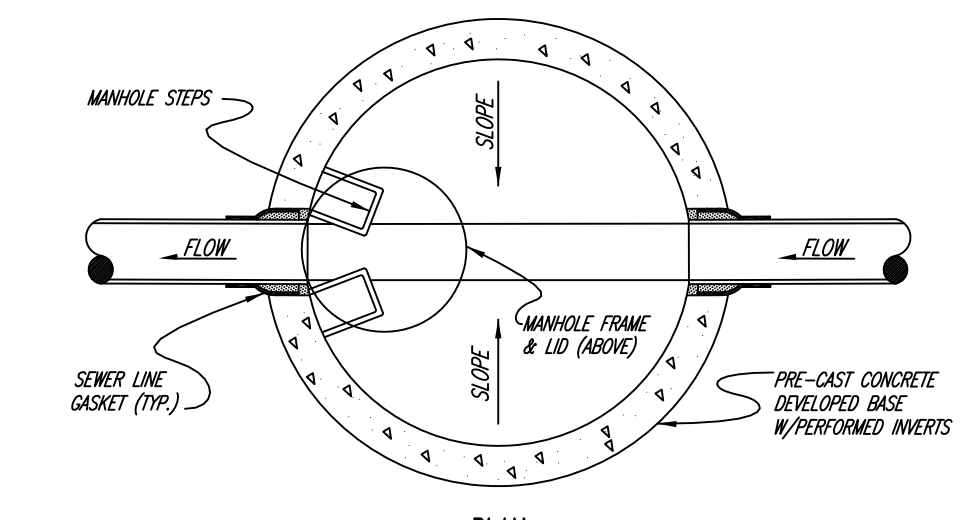
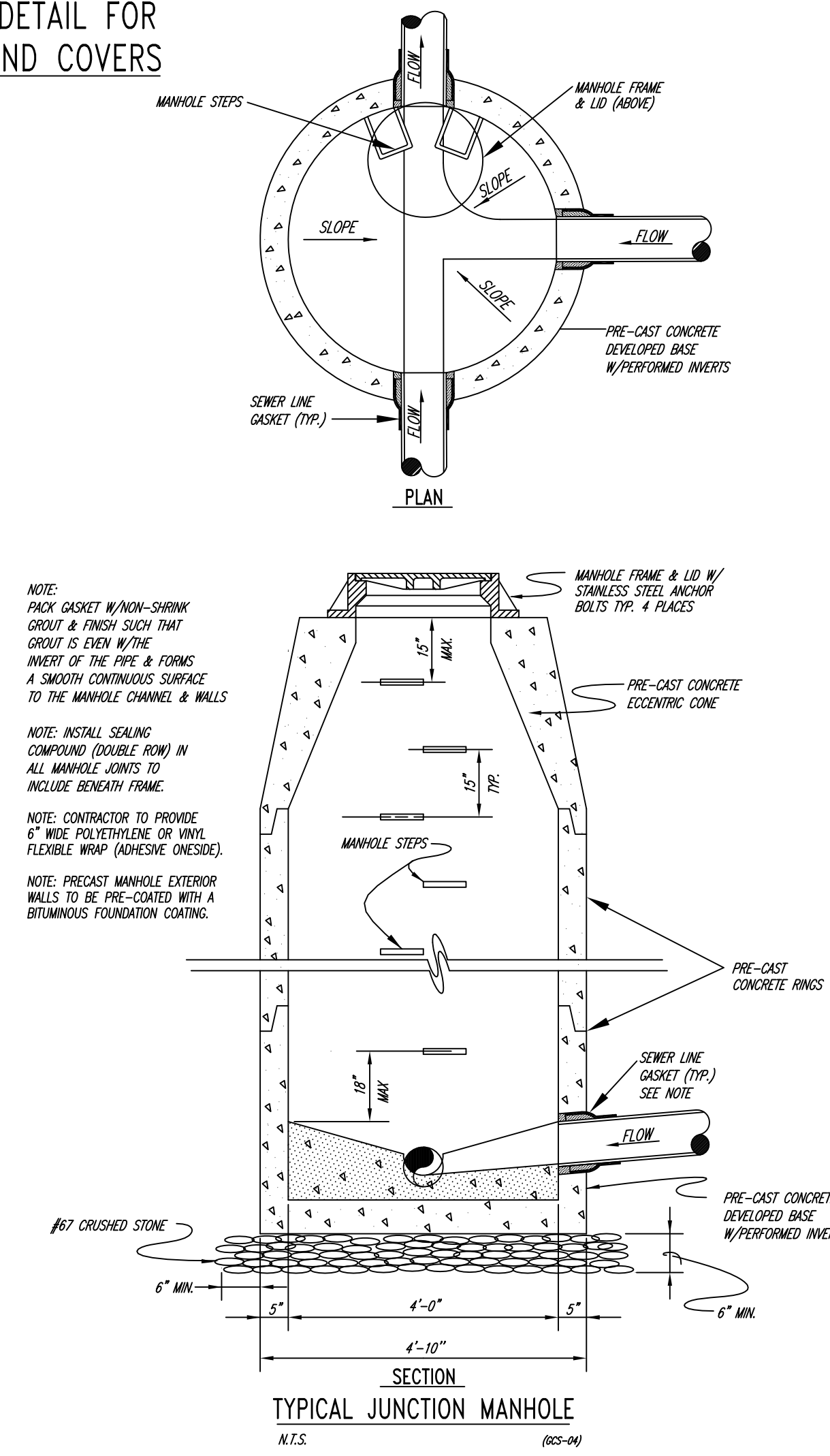
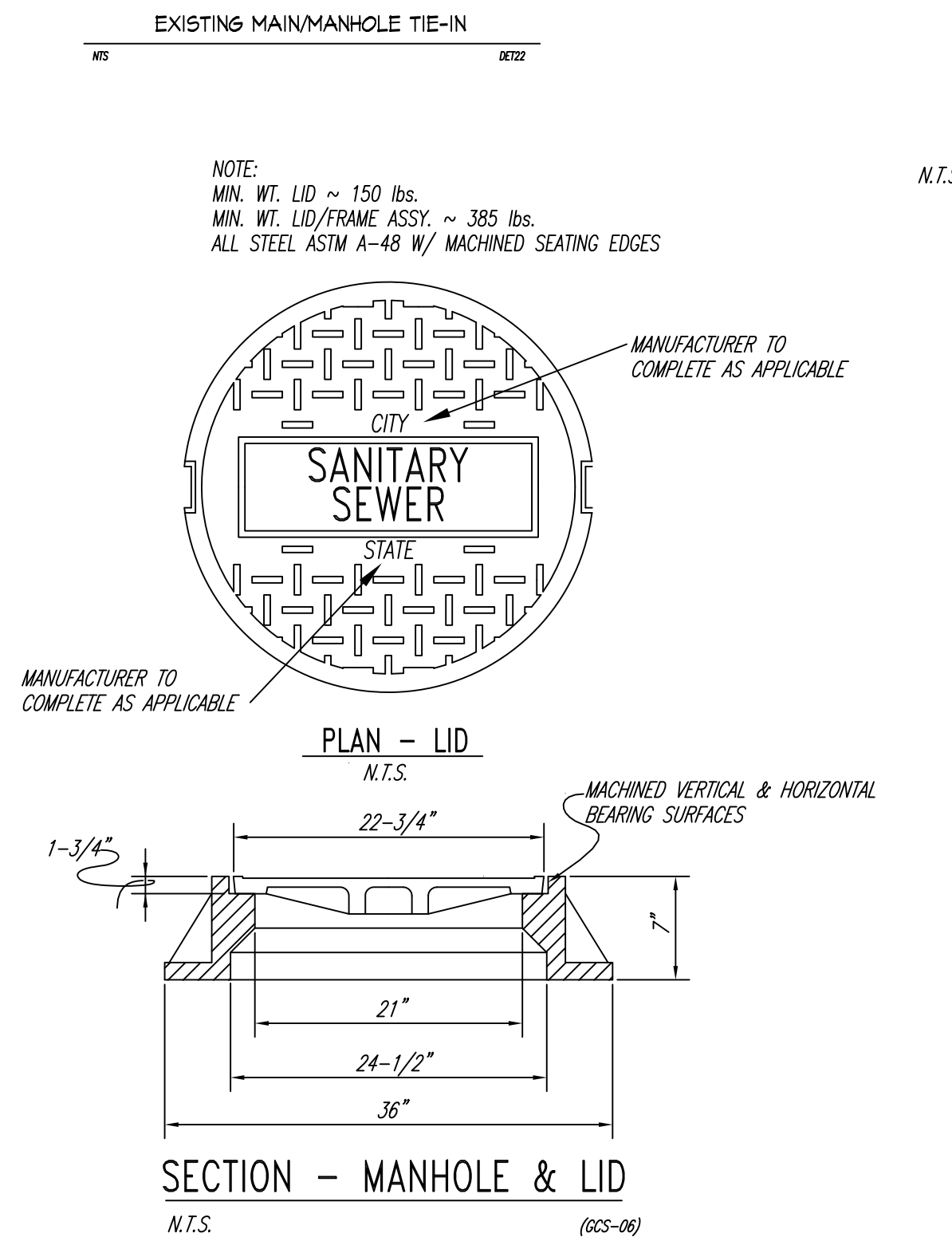
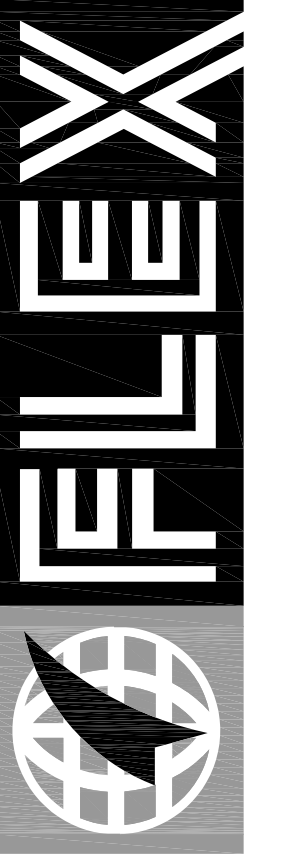

FLEXFILMS, U.S.A., LLC  
1221 NORTH BLACK BRANCH ROAD  
ELIZABETHTOWN, KENTUCKY 42702

PROJECT L-12 BOPET U.S.A.

DATE	POST BID REVISIONS	REVISION	BY	SCALE
1-2012			SCAC	

PROJECT NO.	DESIGNED BY	CHECKED BY	DATE	SCALE
2064-25	E.G.M.	J.R.M.	JULY 2011	AS SHOWN

Engineers  
Architects  
Planners  
**nsc**  
OF KENTUCKY, INC.  
624 Wallington Way  
Lexington, KY 40503  
www.nscinc.com  
Phone: (859)223-5684  
Fax: (859)223-2607

DRAWING NO.  
UFL-L12  
C111.1

JAN 24 X:\2064-25 FLEX FILM - ELIZABETHTOWN TJ PATTERSON INDUSTRIAL PARK\SAN SEWER\C-111 SANITARY SEWER.DWG